

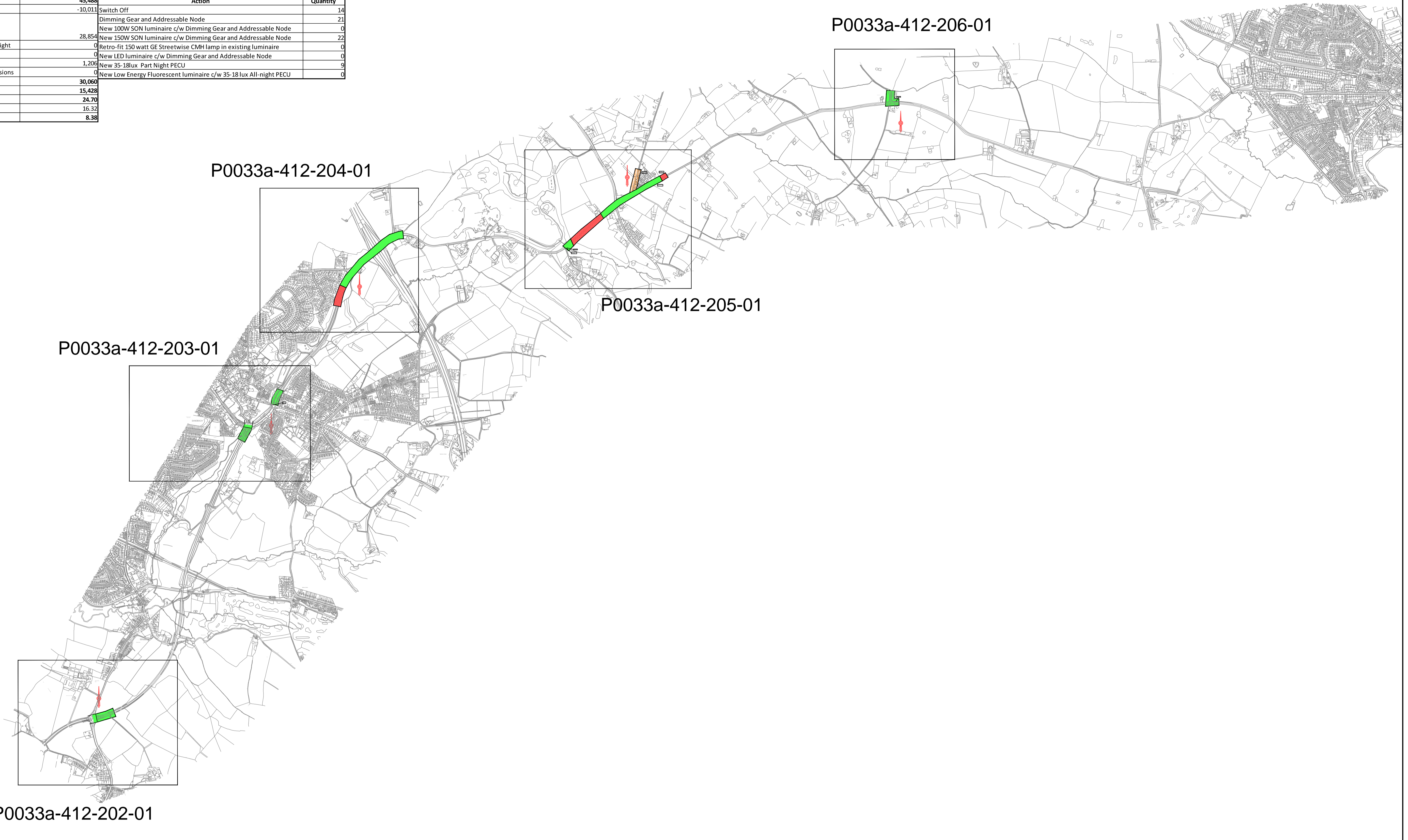

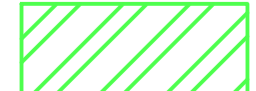



Energy & Carbon Summary		Actions Summary	
Energy Reduction		Action	
Existing Annual Energy (kWhrs)	45,488		Quantity
Switch off (energy removed)	-10,011	Switch Off	14
Dimming	28,854	Dimming Gear and Addressable Node	21
		New 100W SON luminaire c/w Dimming Gear and Addressable Node	0
		New 150W SON luminaire c/w Dimming Gear and Addressable Node	22
Retro-fit GE Streetwise White Light	0	Retro-fit 150 watt GE Streetwise CMH lamp in existing luminaire	0
LED Conversions	0	New LED luminaire c/w Dimming Gear and Addressable Node	0
Part Night Lighting	1,209	New 35-18lux Part Night PECU	9
Low Energy Fluorescent conversions	0	New Low Energy Fluorescent luminaire c/w 35-18 lux All-night PECU	0
New Annual Energy (kWhrs)	30,060		
Reduction (kWhrs)	15,428		
Existing Carbon (tonnes p.a.)	24.70		
New Carbon (tonnes p.a.)	16.32		
Carbon Reduction (tonnes p.a.)	8.38		

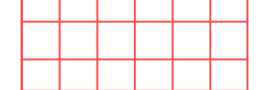

This Map is based upon Ordnance Survey material with the permission of Ordnance Survey on behalf of the Controller of Her Majesty's Stationery Office © Crown copyright. Unauthorised reproduction infringes Crown copyright and may lead to prosecution or civil proceedings. Cheshire East Council 2012

Key:			
	LIGHTING TO REMAIN (WITH DIMMING)		LIGHTING TO BE REPLACED WITH L.E.D
	SWITCH OFF		PART NIGHT
	LOW ENERGY FLUORESCENT		EXTENTS OF SURVEYED LIGHTING

Notes:
EXTENTS OF DIMMING AT ROUNDABOUTS IS FOR INDICATIVE PURPOSES ONLY. PLEASE SEE SCHEDULE OF LIGHTING FOR FULL DETAILS.

Rev.	Description	Drawn	Check	App.	Date
01	Site Assessment Not For Construction	RG	AP	AW	07/12



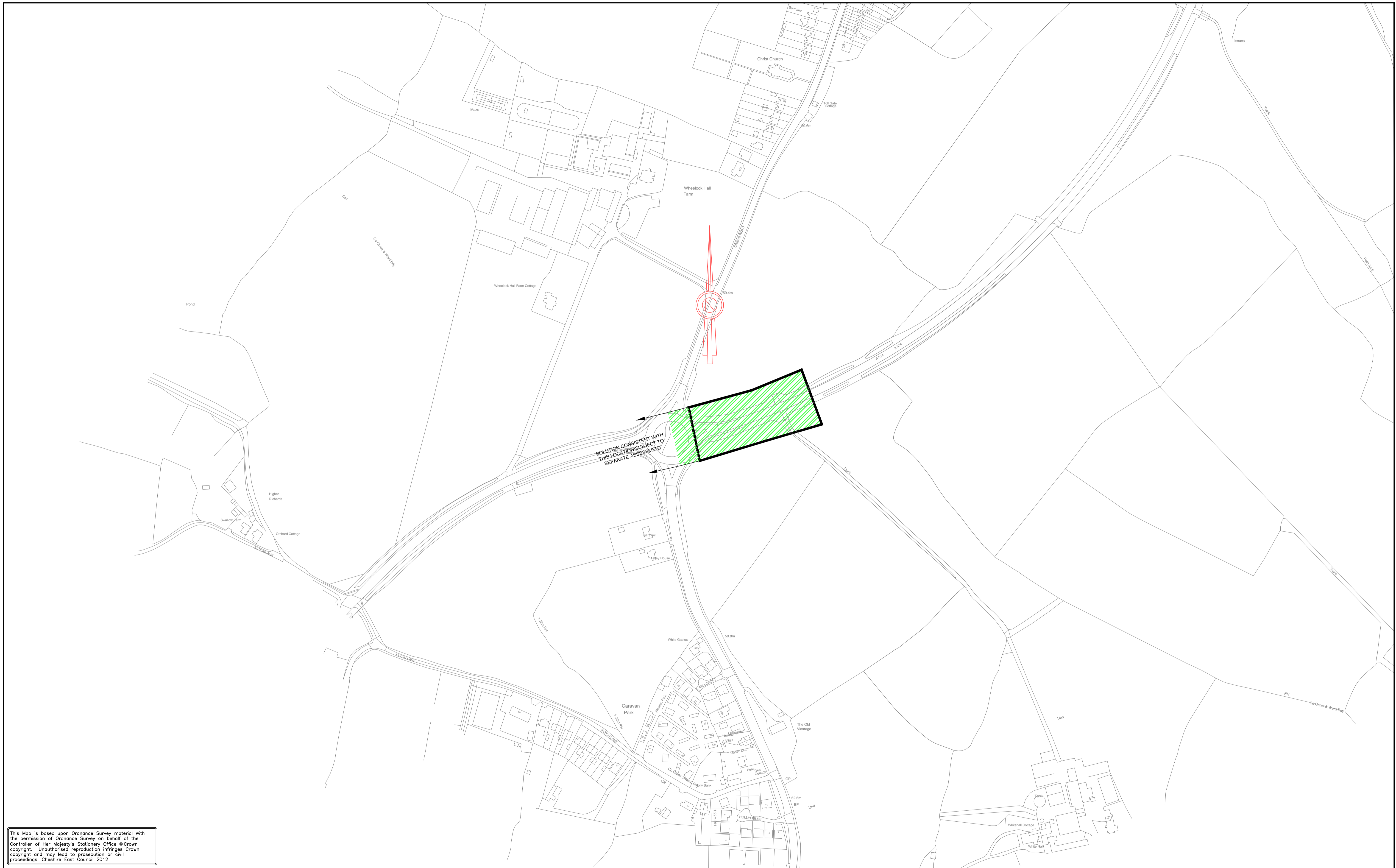

Project
Cheshire East Council
Street Lighting Energy Reduction Strategy

Drawing
ZONE 412
Site Assessment

Scale(s): NOT TO SCALE			
Drawn: RG	Checked: AP	Approved: AW	Date: JULY 12
Drawing No: P0033a-412-201-01			Revision: 01

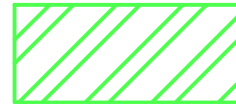
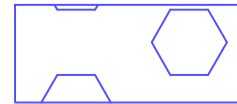

This Map is based upon Ordnance Survey material with the permission of Ordnance Survey on behalf of the Controller of Her Majesty's Stationery Office © Crown copyright. Unauthorised reproduction infringes Crown copyright and may lead to prosecution or civil proceedings. Cheshire East Council 2012

Key:			
	LIGHTING TO REMAIN (WITH DIMMING)		LIGHTING TO BE REPLACED WITH L.E.D
	SWITCH OFF		LOW ENERGY FLUORESCENT
	PART NIGHT		EXTENTS OF SURVEYED LIGHTING

Notes:
EXTENTS OF DIMMING AT ROUNDABOUTS IS FOR INDICATIVE PURPOSES ONLY. PLEASE SEE SCHEDULE OF LIGHTING FOR FULL DETAILS.

Rev.	Description	Drawn	Check	App.	Date
01	Site Assessment Not For Construction	RG	AP	AW	07/12

Cheshire East Council
Street Lighting Energy Reduction Strategy



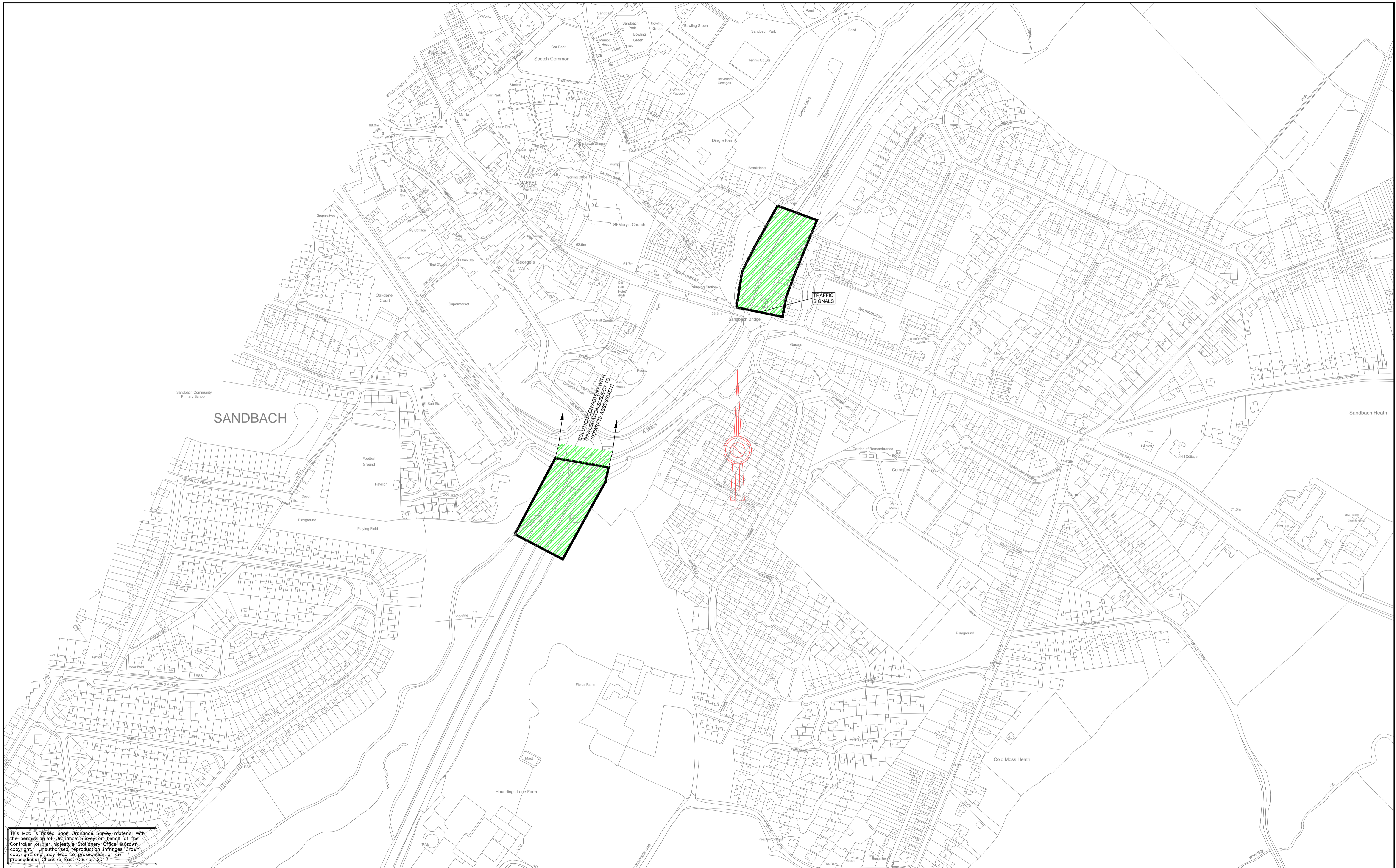

Drawing
ZONE 412
Site Assessment

Scale(s): 1:2000 @ A1			
Drawn: RG	Checked: AP	Approved: AW	Date: JULY 12
Drawing No: P0033a-412-202-01			Revision: 01

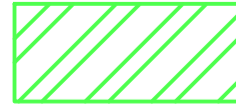
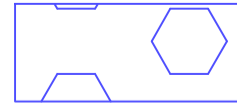
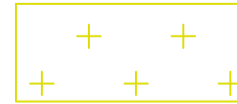

This Map is based upon Ordnance Survey material with the permission of Ordnance Survey on behalf of the Controller of Her Majesty's Stationery Office © Crown copyright. Unauthorised reproduction infringes Crown copyright and may lead to prosecution or civil proceedings. Cheshire East Council 2012

Key:

	LIGHTING TO REMAIN (WITH DIMMING)		LIGHTING TO BE REPLACED WITH L.E.D		LOW ENERGY FLUORESCENT
	SWITCH OFF		PART NIGHT		EXTENTS OF SURVEYED LIGHTING

Notes:

EXTENTS OF DIMMING AT ROUNDABOUTS IS FOR INDICATIVE PURPOSES ONLY. PLEASE SEE SCHEDULE OF LIGHTING FOR FULL DETAILS.

01	Site Assessment Not For Construction	RG	AP	AW	07/12
Rev.	Description	Drawn	Check	App.	Date

Project
Cheshire East Council
Street Lighting Energy Reduction Strategy

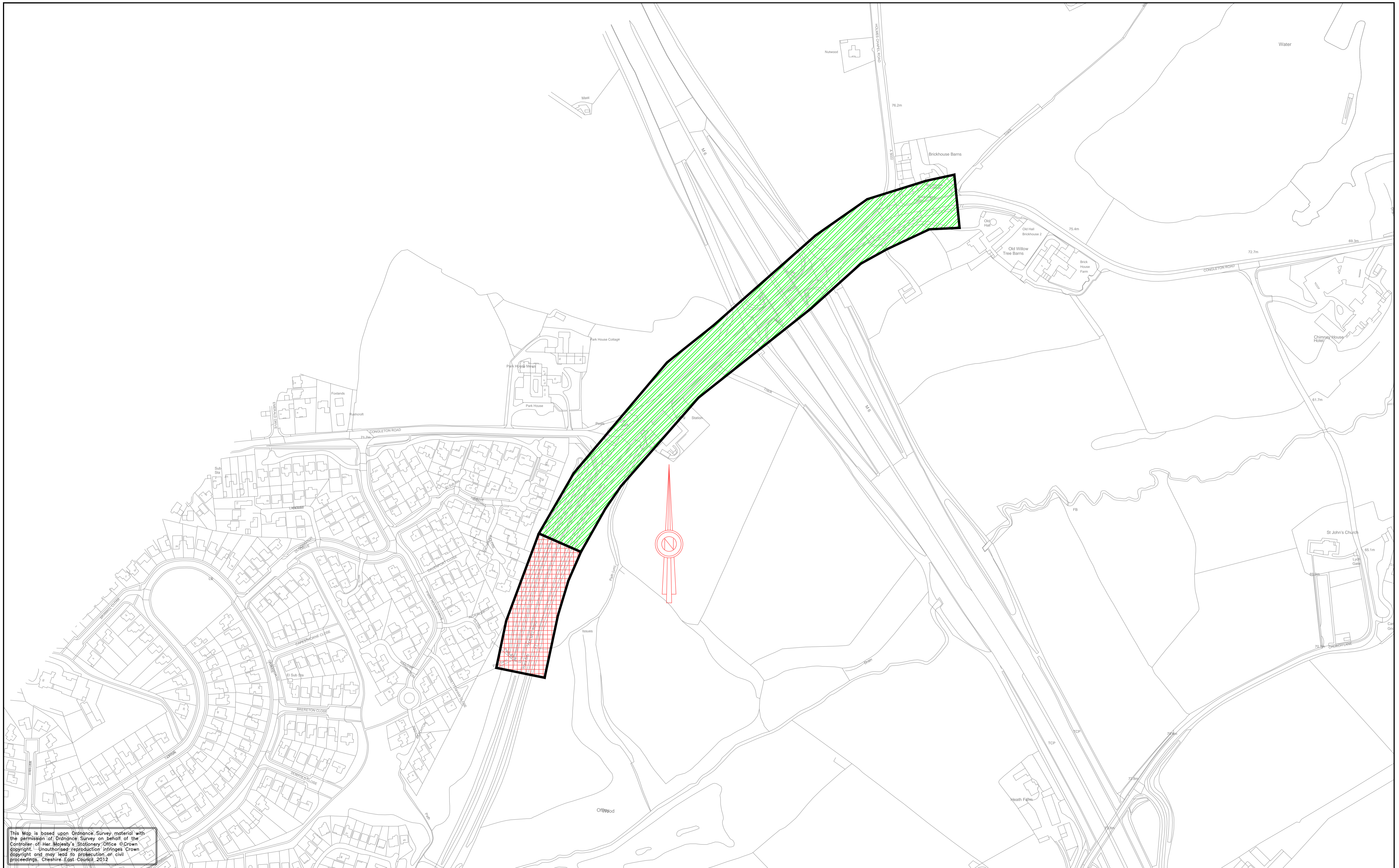

Drawing
ZONE 412
Site Assessment

Scale(s): 1:2000 @ A1			
Drawn: RG	Checked: AP	Approved: AW	Date: JULY 12
Drawing No: P0033a-412-203-01			Revision: 01

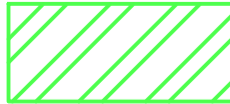
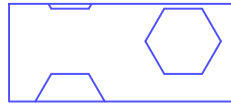
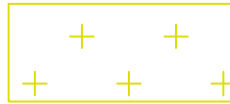
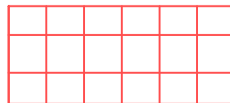

This Map is based upon Ordnance Survey material with the permission of Ordnance Survey on behalf of the Controller of Her Majesty's Stationery Office © Crown copyright. Unauthorised reproduction infringes Crown copyright and may lead to prosecution or civil proceedings. Cheshire East Council 2012

Key:

	LIGHTING TO REMAIN (WITH DIMMING)		LIGHTING TO BE REPLACED WITH L.E.D		LOW ENERGY FLUORESCENT
	SWITCH OFF		PART NIGHT		EXTENTS OF SURVEYED LIGHTING

Notes:
EXTENTS OF DIMMING AT ROUNDABOUTS IS FOR INDICATIVE PURPOSES ONLY. PLEASE SEE SCHEDULE OF LIGHTING FOR FULL DETAILS.

01	Site Assessment Not For Construction	RG	AP	AW	07/12
Rev.	Description	Drawn	Check	App.	Date



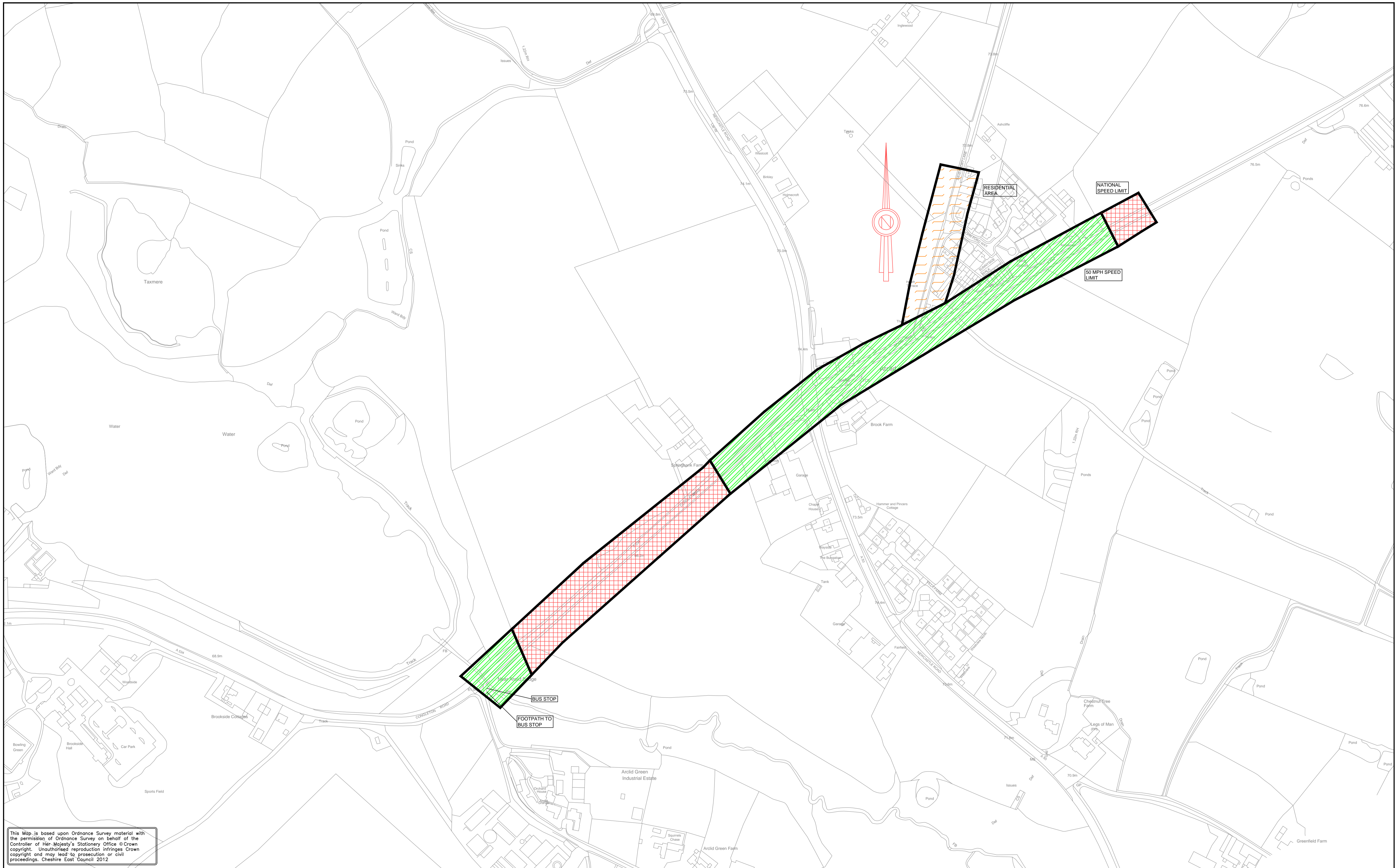

Cheshire East Council
Street Lighting Energy Reduction Strategy

ZONE 412
Site Assessment

Scale(s): 1:2000 @ A1			
Drawn: RG	Checked: AP	Approved: AW	Date: JULY 12
Drawing No: P0033a-412-204-01			Revision: 01

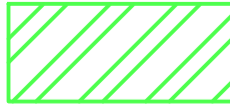
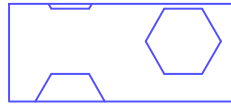
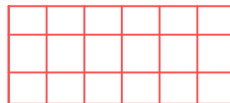

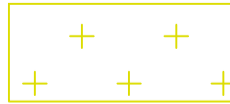
This Map is based upon Ordnance Survey material with the permission of Ordnance Survey on behalf of the Controller of Her Majesty's Stationery Office © Crown copyright. Unauthorised reproduction infringes Crown copyright and may lead to prosecution or civil proceedings. Cheshire East Council 2012

Key:			
	LIGHTING TO REMAIN (WITH DIMMING)		LIGHTING TO BE REPLACED WITH L.E.D
	SWITCH OFF		PART NIGHT
	LOW ENERGY FLUORESCENT		EXTENTS OF SURVEYED LIGHTING

Notes:
EXTENTS OF DIMMING AT ROUNDABOUTS IS FOR INDICATIVE PURPOSES ONLY. PLEASE SEE SCHEDULE OF LIGHTING FOR FULL DETAILS.

Rev.	Description	Drawn	Check	App.	Date
01	Site Assessment Not For Construction	RG	AP	AW	07/12



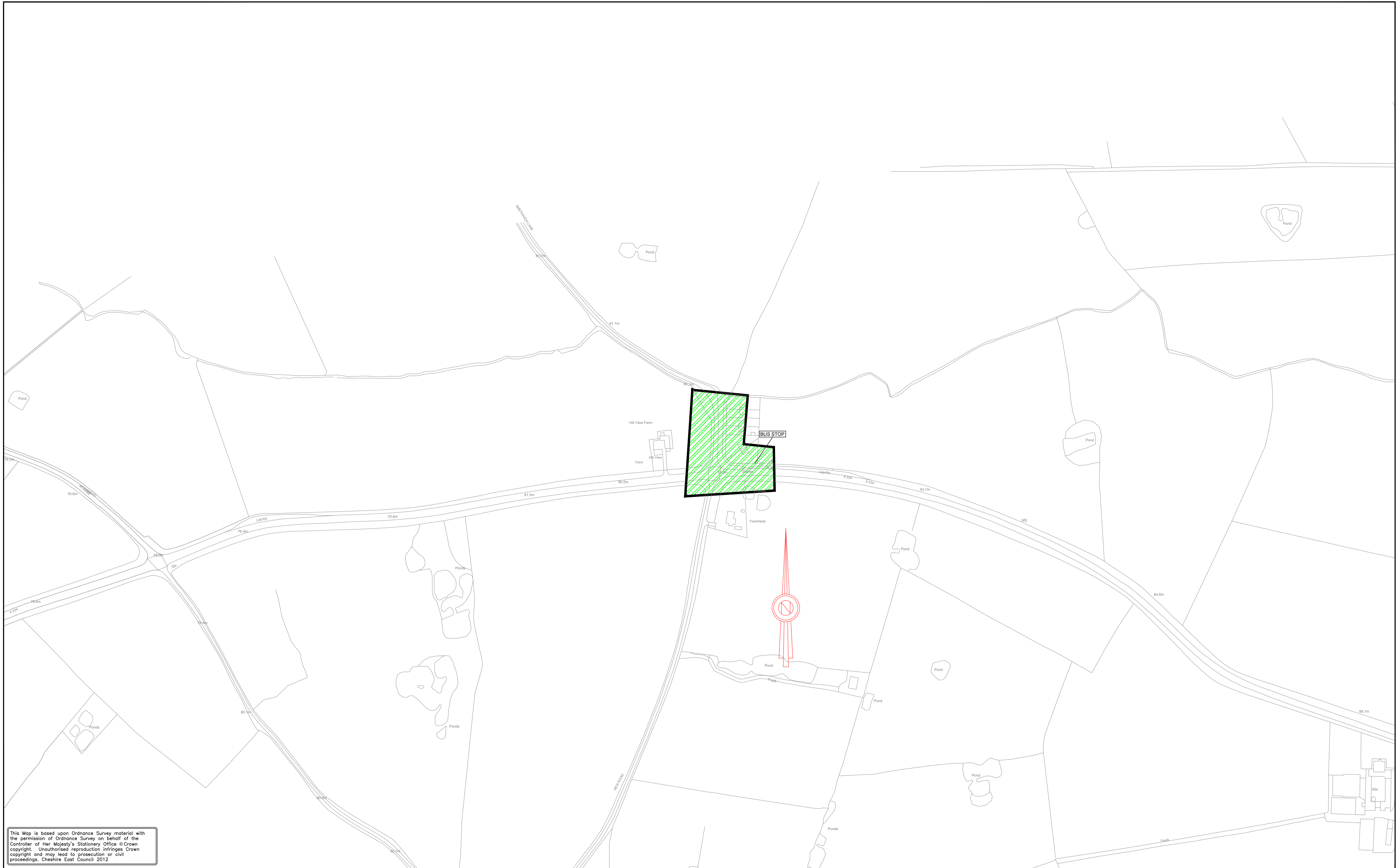

Cheshire East Council
Street Lighting Energy Reduction Strategy

ZONE 412
Site Assessment

Scale(s): 1:2000 @A1			
Drawn: RG	Checked: AP	Approved: AW	Date: JULY 12
Drawing No: P0033a-412-205-01			Revision: 01

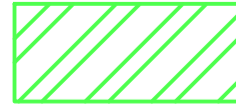
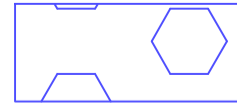

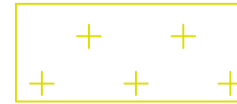
This Map is based upon Ordnance Survey material with the permission of Ordnance Survey on behalf of the Controller of Her Majesty's Stationery Office © Crown copyright. Unauthorised reproduction infringes Crown copyright and may lead to prosecution or civil proceedings. Cheshire East Council 2012

Key:			
	LIGHTING TO REMAIN (WITH DIMMING)		LIGHTING TO BE REPLACED WITH L.E.D
	SWITCH OFF		LOW ENERGY FLUORESCENT
	PART NIGHT		EXTENTS OF SURVEYED LIGHTING

Notes:
 EXTENTS OF DIMMING AT ROUNDABOUTS IS FOR INDICATIVE PURPOSES ONLY. PLEASE SEE SCHEDULE OF LIGHTING FOR FULL DETAILS.

Rev.	Description	Drawn	Check	App.	Date
01	Site Assessment Not For Construction	RG	AP	AW	07/12

Cheshire East Council Street Lighting Energy Reduction Strategy		Scale(s): 1:2000 @ A1	
		Drawn: RG	Checked: AP
ZONE 412 Site Assessment		Approved: AW	Date: JULY 12
		Drawing No: P0033a-412-206-01	Revision: 01